

APPLICATION EXAMPLE ▶ Mechanical Engineering ▶ PET-Mold Core

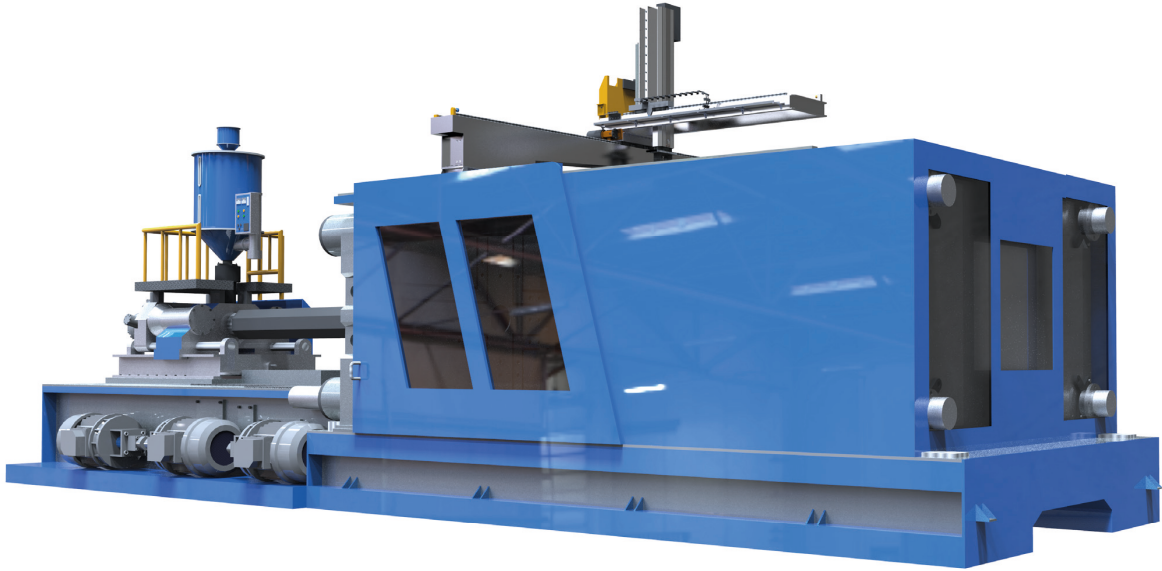

Task

Replace hand-polishing process

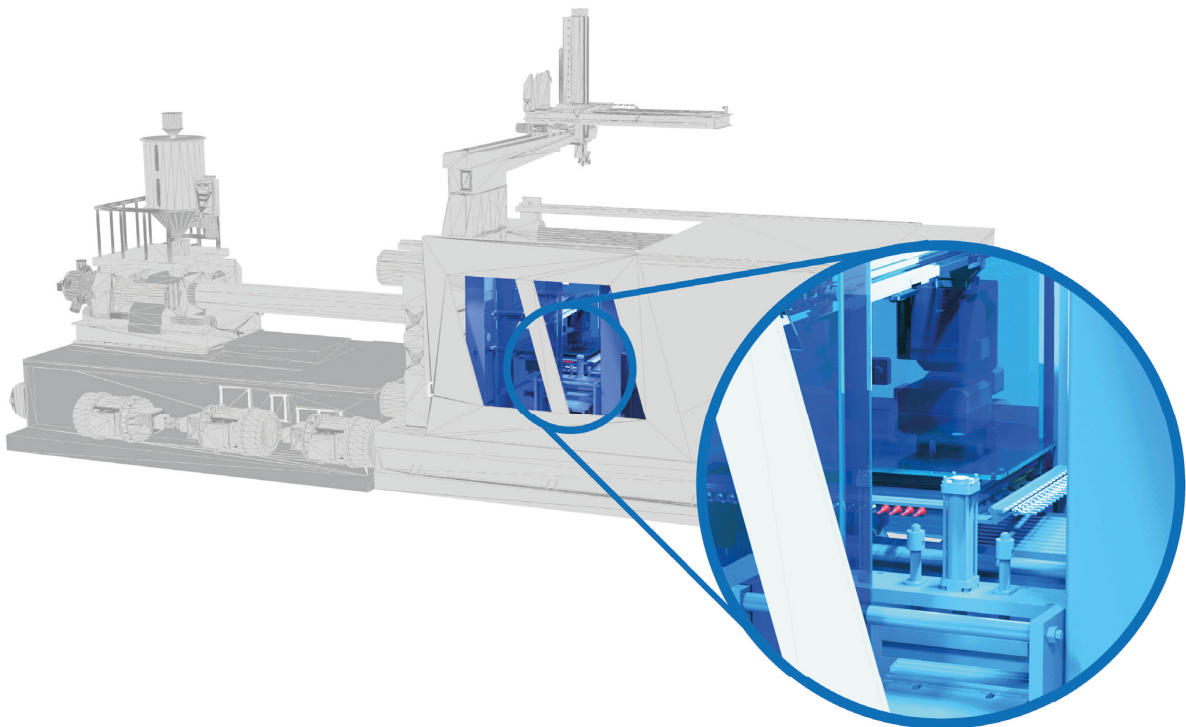



Solution

Two-zone Roller Burnishing of cone and contour with the HG6 tool

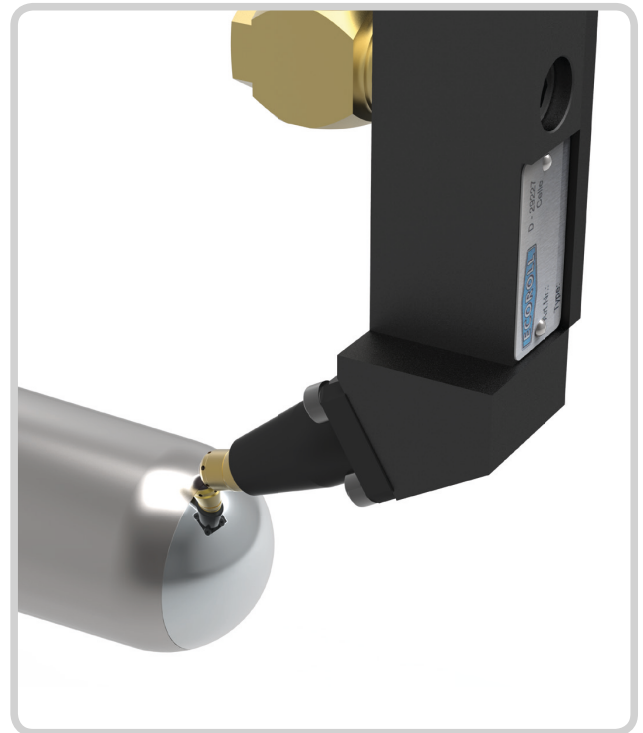
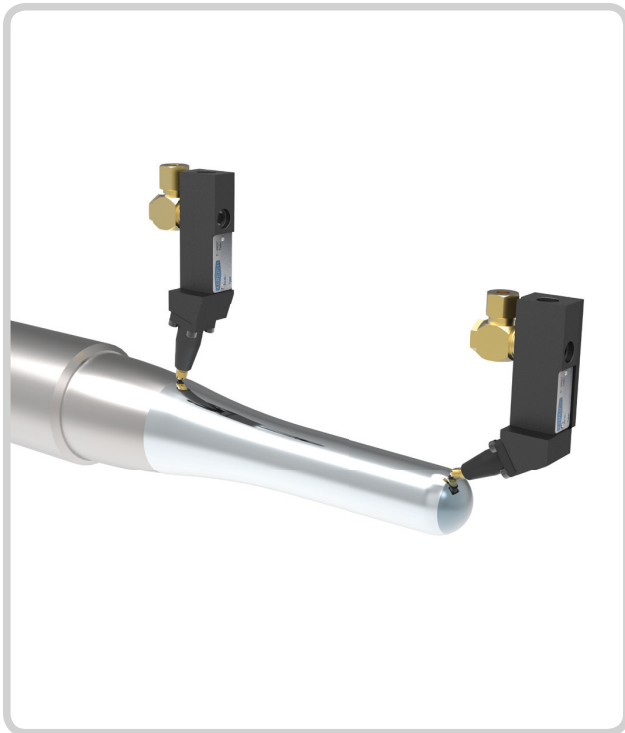

User benefits

- Reduce process time by about **25%**
- Increase of hardness by about **8%**
- Consistent results

Details

- Workpiece PET-Mold Core
- Part of Molding machine
- Material Hardened steel
- Hardness 55 HRC

Parameter

- Tool HG6-9L65° + L15°
- Circumferential speed ... 110 m/min
- Feed rate 0,1 mm/rev.
- Cycle time 45 seconds